

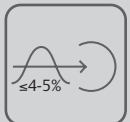

Power Quality Solutions

## Liebert Hipulse E

### Hi-Availability UPS



*Input Total  
Current Harmonics*

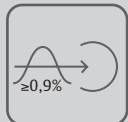

*Input Power  
Factor*

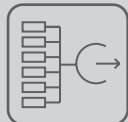

*Expandable up to  
Six UPS modules*



*Wide Input Voltage  
& Frequency Ranges*

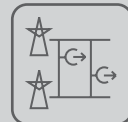

*Multi Bus  
Compatible*

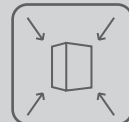

*Compact  
Footprint*

# Liebert Hipulse E

## Hi-Availability UPS



The increased sophistication of critical & hyper critical applications in today's digital world and the enhanced dependence of your business on such applications have led Emerson Network Power to design Liebert Hipulse E UPS to provide you high availability of quality power.

Having extensively captured the customer needs and thoroughly mapped the same through 360° value analysis, Hipulse E has been carefully designed to deliver high value: investment ratio.

The proven performance & reliability of Liebert's Hipulse series, combined with customer delight and value added features have made Liebert Hipulse E the obvious choice across the globe.

From reliability to availability, from scalability to redundancy, from user-friendliness to maintainability, from parallelability to connectivity, from investment protection to lower cost of ownership, whichever value you need, Liebert Hipulse E addresses them all efficiently and effectively, better than the best in the industry.

Liebert Hipulse E, as one of the prime members of our array of power quality solutions, is providing the 360° value

across the globe for almost all the conceivable critical applications, some of which are listed below for your ready references.

Liebert Hipulse E (with true on-line double conversion topology) comes in eight popular ratings, ranging from 120 to 800 kVA (400V, 50/60 Hz). Carefully picked up feature-set to address appropriate customer value is one of the prime objectives to achieve high "availability-to-price" (ATP) ratio.

### Major Applications of Liebert Hipulse E are:

- Information Technology
  - Data Centres
  - Servers (LAN, WAN, MAN, ERP, e-mail, web and others)
  - Networking
- Telecommunication
  - Mobile (2G, 2.5G, 3G and the likes)
  - Paging
  - Fixed (including WiLL)
- Industrial Automation
  - Process (including instrumentation)
  - Motion (digital drives & robotics)
- Transport Automation
  - Airport automation and flight booking
  - Others including railways & road transport automation & ticket booking
- Banking, Insurance and Financial Services
- Software Development Houses / Software Technology Parks (STP)
- Building Automation
  - Access Control
  - Security System
  - Fire Alarm System
  - Emergency Lighting
  - Other Critical Applications
- Medical Diagnostics
  - Magneto Resonant Imaging (MRI)
  - CT Scanning
  - CathLab
- Satellite
  - Uplinking
  - Earth Stations



Information Technology



Data Center Rooms



Telecom Facilities



Network

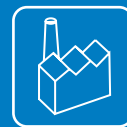

Industrial Facilities



Medical Diagnostics

## Top 10 Customer Values addressed by Liebert Hipulse E are:

- Hi-Availability of Quality Power by way of system redundancy (parallelibility up to 6 UPS modules with or without Main Static Switch called MSS) and multi bus configuration using HiSync & HiSwitch
- Upstream Green Power achieved through low input current THD & high input power factor using different solutions by way of 6-pulse with harmonic filter or 12-pulse with harmonic filter, depending on the requirement
- Reduced Cost of Ownership by way of improved input power factor (reducing electricity bill) and compact gross footprint (reducing active & passive occupied spaces)
- Ease & simplicity in Expendibility & Redundancy with the parallelibility up to 6 modules with or without Main Static Switch (MSS)
- Investment Protection (for upstream semi-critical loads, UPS, battery and downstream critical loads) by way of reasonably wide input voltage & frequency tolerances (minimizing the events of battery discharging), optional temperature-compensated battery charging, back-feed protection, short-circuit-proof inverter.
- Maintainability by way of built-in maintenance bypass, optional wrap-around maintenance bypass, electrical interlocking system, redundant configuration (allowing you to maintain the redundant modules) and dual bus compatibility (enabling you to transfer the load to alternate bus)



- Serviceability by means of front accessibility of critical components, event logging with date & time stamping, hours-run indication and wide-angle (>180°) door-opening
- Flexibility in decision making through innumerable choices to pick from (e.g. type of battery, number of configurations, myriad combinations of 6 or 12-pulse with or without filter and array of internal & external power & communication options)
- User flexibility (choices of 5-language LCD, adjustable power walk-in, making myriad user-specified settings, having data through innumerable power communications alternatives etc.) and user friendliness (menu-driven LCD with detailed data reporting)
- Power Communications with the use of Relay Card, SNMP Web Card, ModBus / Jbus Card, MultiLink Software etc. Each one is designed to address the specific needs of each business function. For example, SNMP Web Card will be useful for your Network Manager, while the ModBus / Jbus Card will be more desirable to your Facility Manager.

Having understood & captured the customer needs across the world, the prime focus of the European Product Development Team of Liebert was to achieve a high level of value innovations to provide considerable value to you. Hipulse-E is a solution of that European initiative of Liebert, which offers you the best-in-class value.

## Value-Added Features

Having thoroughly understood & captured the present, latest & anticipated customer needs across the world, the Product Management Team of Liebert Hiross has come out with the following value-added features for your hyper critical applications.

### Utility-Friendly & Generator-Friendly

Liebert Hipulse E with its 12-pulse rectifier version, considering in-built optional harmonic filter, is extremely utility-friendly. In this configuration, Hipulse E achieves <4-5% input current THD (Total Harmonic Distortion) and  $\geq 0.90$  input power factor (PF). The former one (the THD) ensures almost clean power in the upstream avoiding pollution and thus damage to the other semi-critical loads connected to the upstream power distribution bus. Moreover, it also ensures lower investments in cable costs (due to reduced cable size). The later one (the PF) helps you maximising active power leading to saving in cost of ownership (in terms of lesser electricity bill) and also ensures reduced investment towards motor generator set (by way of minimising its sizing), making it generator-friendly. Overall, Hipulse-E is an Utility-Friendly & Generator-Friendly system employing this appropriate solution.

### Horizontal Xpandability & Redundancy

Liebert Hipulse E is designed to parallel up to as high as six (6) UPS modules to achieve either capacity or redundancy. The system can grow (through horizontal xpandability) as your business grows or the system can provide you higher availability, as your business demands it. Achieving parallelibility up to six modules can be achieved with or without the centralized static switch & centralized controller. Thanks to Liebert's unmatched paralleling technique to provide you with both the alternatives aptly needed for large power UPS configurations.

### Multi Bus Compatibility

Liebert Hipulse E has the feature of achieving multi bus configurations by the use of optional HiSync (to ensure synchronisation among the multi bus systems) and optional HiSwitch or Liebert HiSwitch2 (the static transfer switches). This configuration will allow you to automatically transfer power (from one bus to the other, whenever the need arises). This gives you significant values to ensure high availability (Hi 9's) of quality power. We have successfully executed multiple projects of 2-bus, 3-bus & 4-bus systems with HiSynch & HiSwitch. This is what made Hipulse the best-in-class High Availability UPS system. Liebert Hipulse E is an enhanced version of that Hipulse.

### Flexi Power Walk-In

Liebert Hipulse E is designed to have flexible power walk-in (another unique feature) by way of adjusting the power walk-in from 5 seconds to 120 seconds. This gives you the opportunity to have optimized motor generator sizing (leading to reduced investment for you) and the user flexibility to have different walk-in time period for different paralleled UPS modules (offering user flexibility).

### Temperature Compensated Battery Charging

Liebert Hipulse E allows the user to use optional temperature monitoring kit (to be connected to the battery bank) to monitor the temperature of the battery and thereby controlling the battery charging voltage. This helps you to protect the battery investment by way of protecting the battery health.

### Compact Active & Passive Footprints

Liebert Hipulse E is designed to minimize both the active & passive footprints. As you know, the active footprint is the physical, visible & actual floor space occupied by the cabinet. The passive one is invisible-but-IMPLIED space needed for the thermal management &/or accessing critical components like PCB's (Printed Circuit Boards), Capacitors, Fans etc. Hipulse E employs simple thermal management and front-access layouting objective. The cool air is drawn from the front and the hot air is expelled out from the top. This is how Hipulse E offers you a compact gross footprint, reducing your cost of ownership to the lowest possible level.

Hipulse E can house anyone of the following remote power communication aids by means of the following optional hardware:

- Configurable Relay Card (to address the basic need of a user/maintenance persons)
- Open Comms Web Card (to address the needs of a network manager)
- ModBus / Jbus Card (to address the needs of a facility manager)

## Other Remote Communications

Liebert Hipulse E also provides other communications alternatives through RS-232 & RS-485 ports and through HiroLink, IGMNet protocols. These provide you with the opportunity to integrate the communication system with our High Performance Air Conditioning (HPAC) systems. Other than utilizing RS-232 port for remote communication, it can also be used for local downloading of data for the service engineers, while the RS-485 port can be utilized to have remote communications of myriad applications.

## Local Communications

Liebert Hipulse E provides excellent local communications by way of its Man-Machine Interface (MMI). The MMI of Hipulse E uses some important push buttons (including “Emergency Power Off” :EPO with a transparent cover), LED-based MIMIC diagram and a LCD. While the MIMIC shows you the live power path, the back-lit LCD provides you with the requisite parameters of the unit in six (6) different languages (can be chosen from 8 different languages at the ordering stage) through user-friendly menu including event history with date & time stampings.

## Customer Values are Mapped to Major Features of Liebert Hipulse E for ready References

Need Categories	Feature-Need Value Matrix	Protection			System						Communication						
	Customer Needs	Back-Feed Protection	Dc Ground Fault Detection (option)	Short Circuit protected inverter	6-IGBT based PWM Invert	High Overload Handling Capability	Hot Standby Configuration	Parallelable up 6 (six) UPS Units without MSS	Parallelable up 6 (six) UPS Units	Dual Bus Compatibility	Event History on LCD	8-Language LCD (5: Standards, 3 optional)	Remote Alarm Monitor (RAM)	OpenComms Web Card	ModBus//bus / JBus Card	Programmable Relay Card	Hirolink
Financial Needs	Reduced Investment																
	Lower Cost of Ownership																
	Investment Protection	●	●	●	●	●											
Application & Business Needs	Reliability				●												
	Hi Availability of Q Power					●	●	●	●	●							
	Scalability							●	●	●							
	Redundancy						●	●	●	●							
	Maintainability						●	●	●	●							
Application & Business Needs	Safety	●	●	●													
	Input Quality Power																
	Output Quality Power				●												
	User Friendliness				●						●	●	●	●	●	●	●
	User Flexibility						●	●	●	●			●	●	●	●	●
	Power Communication												●	●	●	●	●
	Compactness																
Serviceability	●									●	●	●	●	●	●	●	
Intangible & Latent Needs	Decision Making Flexibility					●	●	●	●	●							
	Customer Confidence																
	Simplicity & Aesthetics						●	●	●	●	●						

# Customer Values are Mapped to Major Features of Liebert Hipulse E for Ready references

		Feature-Need Matrix		Input				DC Circuit & Battery				Static Bypass																																																																																																																																																																																																																																																																																																																																									
Need Categories	Customer Needs	Features		Input Current THDI <5% (optional with 12 p+Filter)	Input Power Factor >= 0.98 (optional with 12 p+Filter)	Input Voltage Range (323-477 V)	Input Frequency Range (47-63 Hz)	Input Frequency: 50 or 60 Hz	Adjustable Power Walk-In	DC Ripple Voltage <1%	Battery Test	Long Battery Discharge at Low Load	Battery Temperature Compensated Charging	Flexibility to use VRLA or Wet or NiCd Battery	Overloading Condition of 1000% for 10 msecs	Frequency Adjustment Range	Auto Retransferring Facility																																																																																																																																																																																																																																																																																																																																				
		Financial Needs	Reduced Investment		●		●				●									Lower Cost of Ownership			●															Investment Protection			●			●	●			●	●	●	●					Application & Business Needs	Reliability																	Hi Availability of Q Power						●	●		●					●			●	Scalability																		Redundancy																		Maintainability																		Operational Needs	Safety																	Input Quality Power			●		●													Output Quality Power																		User Friendliness																		User Flexibility								●	●			●				●		Power Communication																		Compactness																		Serviceability																		Intangible & Latent Needs	Decision Making Flexibility													●				Customer Confidence										●	●							Simplicity & Aesthetics															
Lower Cost of Ownership			●															Investment Protection			●			●	●			●	●	●	●					Application & Business Needs	Reliability																	Hi Availability of Q Power						●	●		●					●			●	Scalability																		Redundancy																		Maintainability																		Operational Needs	Safety																	Input Quality Power			●		●													Output Quality Power																		User Friendliness																		User Flexibility								●	●			●				●		Power Communication																		Compactness																		Serviceability																		Intangible & Latent Needs	Decision Making Flexibility													●				Customer Confidence										●	●							Simplicity & Aesthetics																																			
Investment Protection			●			●	●			●	●	●	●					Application & Business Needs	Reliability																	Hi Availability of Q Power						●	●		●					●			●	Scalability																		Redundancy																		Maintainability																		Operational Needs	Safety																	Input Quality Power			●		●													Output Quality Power																		User Friendliness																		User Flexibility								●	●			●				●		Power Communication																		Compactness																		Serviceability																		Intangible & Latent Needs	Decision Making Flexibility													●				Customer Confidence										●	●							Simplicity & Aesthetics																																																					
Application & Business Needs	Reliability																	Hi Availability of Q Power						●	●		●					●			●	Scalability																		Redundancy																		Maintainability																		Operational Needs	Safety																	Input Quality Power			●		●													Output Quality Power																		User Friendliness																		User Flexibility								●	●			●				●		Power Communication																		Compactness																		Serviceability																		Intangible & Latent Needs	Decision Making Flexibility													●				Customer Confidence										●	●							Simplicity & Aesthetics																																																																							
Hi Availability of Q Power						●	●		●					●			●	Scalability																		Redundancy																		Maintainability																		Operational Needs	Safety																	Input Quality Power			●		●													Output Quality Power																		User Friendliness																		User Flexibility								●	●			●				●		Power Communication																		Compactness																		Serviceability																		Intangible & Latent Needs	Decision Making Flexibility													●				Customer Confidence										●	●							Simplicity & Aesthetics																																																																																									
Scalability																		Redundancy																		Maintainability																		Operational Needs	Safety																	Input Quality Power			●		●													Output Quality Power																		User Friendliness																		User Flexibility								●	●			●				●		Power Communication																		Compactness																		Serviceability																		Intangible & Latent Needs	Decision Making Flexibility													●				Customer Confidence										●	●							Simplicity & Aesthetics																																																																																																											
Redundancy																		Maintainability																		Operational Needs	Safety																	Input Quality Power			●		●													Output Quality Power																		User Friendliness																		User Flexibility								●	●			●				●		Power Communication																		Compactness																		Serviceability																		Intangible & Latent Needs	Decision Making Flexibility													●				Customer Confidence										●	●							Simplicity & Aesthetics																																																																																																																													
Maintainability																		Operational Needs	Safety																	Input Quality Power			●		●													Output Quality Power																		User Friendliness																		User Flexibility								●	●			●				●		Power Communication																		Compactness																		Serviceability																		Intangible & Latent Needs	Decision Making Flexibility													●				Customer Confidence										●	●							Simplicity & Aesthetics																																																																																																																																															
Operational Needs	Safety																	Input Quality Power			●		●													Output Quality Power																		User Friendliness																		User Flexibility								●	●			●				●		Power Communication																		Compactness																		Serviceability																		Intangible & Latent Needs	Decision Making Flexibility													●				Customer Confidence										●	●							Simplicity & Aesthetics																																																																																																																																																																	
Input Quality Power			●		●													Output Quality Power																		User Friendliness																		User Flexibility								●	●			●				●		Power Communication																		Compactness																		Serviceability																		Intangible & Latent Needs	Decision Making Flexibility													●				Customer Confidence										●	●							Simplicity & Aesthetics																																																																																																																																																																																			
Output Quality Power																		User Friendliness																		User Flexibility								●	●			●				●		Power Communication																		Compactness																		Serviceability																		Intangible & Latent Needs	Decision Making Flexibility													●				Customer Confidence										●	●							Simplicity & Aesthetics																																																																																																																																																																																																					
User Friendliness																		User Flexibility								●	●			●				●		Power Communication																		Compactness																		Serviceability																		Intangible & Latent Needs	Decision Making Flexibility													●				Customer Confidence										●	●							Simplicity & Aesthetics																																																																																																																																																																																																																							
User Flexibility								●	●			●				●		Power Communication																		Compactness																		Serviceability																		Intangible & Latent Needs	Decision Making Flexibility													●				Customer Confidence										●	●							Simplicity & Aesthetics																																																																																																																																																																																																																																									
Power Communication																		Compactness																		Serviceability																		Intangible & Latent Needs	Decision Making Flexibility													●				Customer Confidence										●	●							Simplicity & Aesthetics																																																																																																																																																																																																																																																											
Compactness																		Serviceability																		Intangible & Latent Needs	Decision Making Flexibility													●				Customer Confidence										●	●							Simplicity & Aesthetics																																																																																																																																																																																																																																																																													
Serviceability																		Intangible & Latent Needs	Decision Making Flexibility													●				Customer Confidence										●	●							Simplicity & Aesthetics																																																																																																																																																																																																																																																																																															
Intangible & Latent Needs	Decision Making Flexibility													●				Customer Confidence										●	●							Simplicity & Aesthetics																																																																																																																																																																																																																																																																																																																	
Customer Confidence										●	●							Simplicity & Aesthetics																																																																																																																																																																																																																																																																																																																																			
Simplicity & Aesthetics																																																																																																																																																																																																																																																																																																																																																					

		Feature-Need Matrix		Output					Unit				Special Feature Appl.																																																																																																																																																																																																																																																																																																																																								
Need Categories	Customer Needs	Features		Output Voltage THDI <1%	Out Power Factor 0,7 (lag) to Unity	Output Voltage Regulation <1%	Output Frequency Regulation <1%	Output Frequency: 50 or 60 Hz	Small Gross Footprint	Door-Opening >180 degree	Top Venting (out) Fans	Front Access	IP-20 With Door-Opened Condition	Modern Styling	Castle Key Interlock Option	Input Galvanic Isolation Option	Top Cable Entry Option																																																																																																																																																																																																																																																																																																																																				
		Financial Needs	Reduced Investment																	Lower Cost of Ownership																		Investment Protection			●	●	●	●	●	●		●	●				●			Application & Business Needs	Reliability														●	●		Hi Availability of Q Power														●	●			Scalability																		Redundancy																		Maintainability			●															Application & Business Needs	Safety									●			●		●			Input Quality Power																		Output Quality Power			●	●	●	●	●											User Friendliness																		User Flexibility																		Power Communication																		Compactness																		Serviceability										●	●							Intangible & Latent Needs	Decision Making Flexibility														●	●	●	Customer Confidence										●	●				●	●		Simplicity & Aesthetics													●		
Lower Cost of Ownership																		Investment Protection			●	●	●	●	●	●		●	●				●			Application & Business Needs	Reliability														●	●		Hi Availability of Q Power														●	●			Scalability																		Redundancy																		Maintainability			●															Application & Business Needs	Safety									●			●		●			Input Quality Power																		Output Quality Power			●	●	●	●	●											User Friendliness																		User Flexibility																		Power Communication																		Compactness																		Serviceability										●	●							Intangible & Latent Needs	Decision Making Flexibility														●	●	●	Customer Confidence										●	●				●	●		Simplicity & Aesthetics													●																						
Investment Protection			●	●	●	●	●	●		●	●				●			Application & Business Needs	Reliability														●	●		Hi Availability of Q Power														●	●			Scalability																		Redundancy																		Maintainability			●															Application & Business Needs	Safety									●			●		●			Input Quality Power																		Output Quality Power			●	●	●	●	●											User Friendliness																		User Flexibility																		Power Communication																		Compactness																		Serviceability										●	●							Intangible & Latent Needs	Decision Making Flexibility														●	●	●	Customer Confidence										●	●				●	●		Simplicity & Aesthetics													●																																								
Application & Business Needs	Reliability														●	●		Hi Availability of Q Power														●	●			Scalability																		Redundancy																		Maintainability			●															Application & Business Needs	Safety									●			●		●			Input Quality Power																		Output Quality Power			●	●	●	●	●											User Friendliness																		User Flexibility																		Power Communication																		Compactness																		Serviceability										●	●							Intangible & Latent Needs	Decision Making Flexibility														●	●	●	Customer Confidence										●	●				●	●		Simplicity & Aesthetics													●																																																										
Hi Availability of Q Power														●	●			Scalability																		Redundancy																		Maintainability			●															Application & Business Needs	Safety									●			●		●			Input Quality Power																		Output Quality Power			●	●	●	●	●											User Friendliness																		User Flexibility																		Power Communication																		Compactness																		Serviceability										●	●							Intangible & Latent Needs	Decision Making Flexibility														●	●	●	Customer Confidence										●	●				●	●		Simplicity & Aesthetics													●																																																																												
Scalability																		Redundancy																		Maintainability			●															Application & Business Needs	Safety									●			●		●			Input Quality Power																		Output Quality Power			●	●	●	●	●											User Friendliness																		User Flexibility																		Power Communication																		Compactness																		Serviceability										●	●							Intangible & Latent Needs	Decision Making Flexibility														●	●	●	Customer Confidence										●	●				●	●		Simplicity & Aesthetics													●																																																																																														
Redundancy																		Maintainability			●															Application & Business Needs	Safety									●			●		●			Input Quality Power																		Output Quality Power			●	●	●	●	●											User Friendliness																		User Flexibility																		Power Communication																		Compactness																		Serviceability										●	●							Intangible & Latent Needs	Decision Making Flexibility														●	●	●	Customer Confidence										●	●				●	●		Simplicity & Aesthetics													●																																																																																																																
Maintainability			●															Application & Business Needs	Safety									●			●		●			Input Quality Power																		Output Quality Power			●	●	●	●	●											User Friendliness																		User Flexibility																		Power Communication																		Compactness																		Serviceability										●	●							Intangible & Latent Needs	Decision Making Flexibility														●	●	●	Customer Confidence										●	●				●	●		Simplicity & Aesthetics													●																																																																																																																																		
Application & Business Needs	Safety									●			●		●			Input Quality Power																		Output Quality Power			●	●	●	●	●											User Friendliness																		User Flexibility																		Power Communication																		Compactness																		Serviceability										●	●							Intangible & Latent Needs	Decision Making Flexibility														●	●	●	Customer Confidence										●	●				●	●		Simplicity & Aesthetics													●																																																																																																																																																				
Input Quality Power																		Output Quality Power			●	●	●	●	●											User Friendliness																		User Flexibility																		Power Communication																		Compactness																		Serviceability										●	●							Intangible & Latent Needs	Decision Making Flexibility														●	●	●	Customer Confidence										●	●				●	●		Simplicity & Aesthetics													●																																																																																																																																																																						
Output Quality Power			●	●	●	●	●											User Friendliness																		User Flexibility																		Power Communication																		Compactness																		Serviceability										●	●							Intangible & Latent Needs	Decision Making Flexibility														●	●	●	Customer Confidence										●	●				●	●		Simplicity & Aesthetics													●																																																																																																																																																																																								
User Friendliness																		User Flexibility																		Power Communication																		Compactness																		Serviceability										●	●							Intangible & Latent Needs	Decision Making Flexibility														●	●	●	Customer Confidence										●	●				●	●		Simplicity & Aesthetics													●																																																																																																																																																																																																										
User Flexibility																		Power Communication																		Compactness																		Serviceability										●	●							Intangible & Latent Needs	Decision Making Flexibility														●	●	●	Customer Confidence										●	●				●	●		Simplicity & Aesthetics													●																																																																																																																																																																																																																												
Power Communication																		Compactness																		Serviceability										●	●							Intangible & Latent Needs	Decision Making Flexibility														●	●	●	Customer Confidence										●	●				●	●		Simplicity & Aesthetics													●																																																																																																																																																																																																																																														
Compactness																		Serviceability										●	●							Intangible & Latent Needs	Decision Making Flexibility														●	●	●	Customer Confidence										●	●				●	●		Simplicity & Aesthetics													●																																																																																																																																																																																																																																																																
Serviceability										●	●							Intangible & Latent Needs	Decision Making Flexibility														●	●	●	Customer Confidence										●	●				●	●		Simplicity & Aesthetics													●																																																																																																																																																																																																																																																																																		
Intangible & Latent Needs	Decision Making Flexibility														●	●	●	Customer Confidence										●	●				●	●		Simplicity & Aesthetics													●																																																																																																																																																																																																																																																																																																				
Customer Confidence										●	●				●	●		Simplicity & Aesthetics													●																																																																																																																																																																																																																																																																																																																						
Simplicity & Aesthetics													●																																																																																																																																																																																																																																																																																																																																								

# Value-added Power Options

Liebert Hipulse E offers you an array of value-added power options listed below:

## External

- Battery Circuit Breaker (wall or cabinet mounted)
- Battery Cabinet
- Main Static Switch (MSS) for Centralised Static Bypass Switch
- Wrap-Around Maintenance Bypass Cabinet
- Top Cable Entry
- Input Isolation Transformer
- Remote Alarm Monitor (wall mounted)

## Internal

- Paralleling Kit (for 1+5 modules)
- Input Harmonic Filter
- Common Battery Sharing Kit
- Fan Failure Alarm
- Power Communication Option
- IP Protection: IP21 - IP30 - IP31

## Special Feature Applications (SFA's)\*

- Dynamic System Expander (DSE)
- Multi-Bus (2-bus, 3-bus and 4-bus)

\* On request

# Multi Bus Configurations

Liebert Hipulse E is designed to include myriad useful optional configurations. Top 4 are furnished below:

### ■ Hot Stand-by

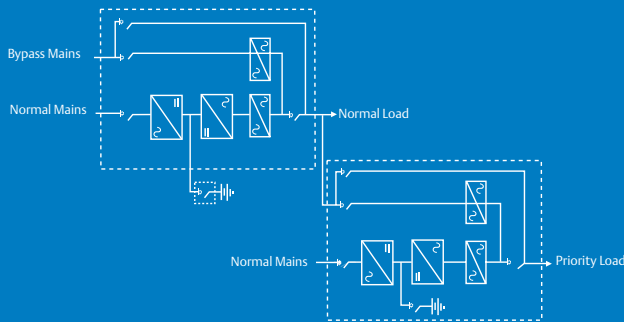

### ■ 1 + N with Distributed Bypass

*Parallel configuration without centralised bypass*

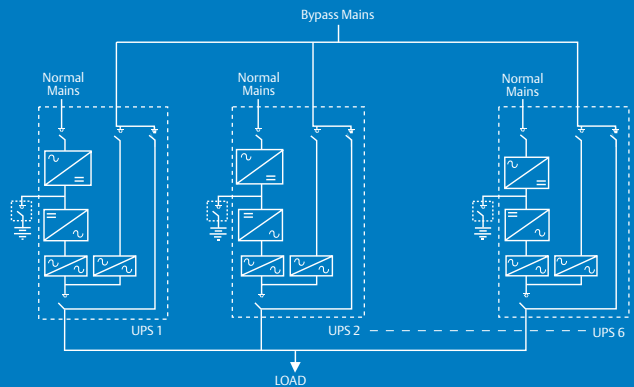

### ■ N + 1 with Centralized Bypass

*Parallel configuration with centralised bypass*

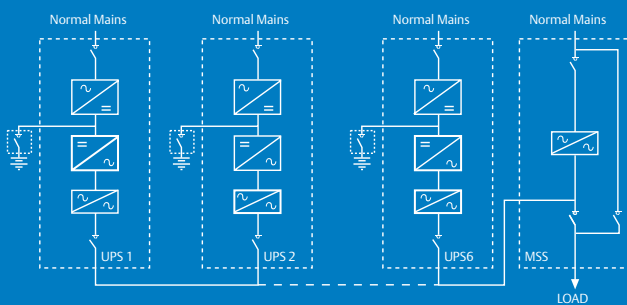

### ■ Multi Bus (2-bus, 3-bus, 4-bus)

*2-bus configuration with HiSwitch2*

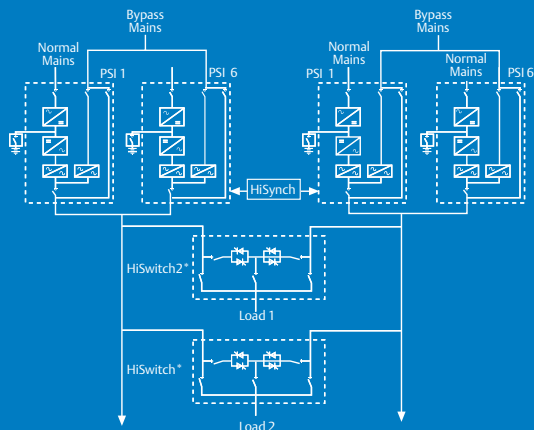

\* Both HiSwitch and HiSwitch2 are compatible

# General Characteristics - [Liebert Hipulse E]

Model Name		Hipulse E								
Nominal Power Rating at 0.8 PF Load	KVA	120	160	200	300	400	500	600	800	
<b>Input Parameters</b>										
Input Voltage to Rectifier	Vac	380/400/415* (400V:nominal) 3-phase, 3-wire								
Input Voltage to Bypass	Vac	380/400/415* (400V:nominal) 3-phase +N, 4-wire								
Permissible Input Voltage Range	Vac	323 to 457								
Input Frequency	Hz	50 or 60								
Permissible Input Frequency Range	Hz	47 or 63								
Input THDi at nominal voltage at full load	%	<4-5% with 12-pulse + Filter								
Input Power Factor at nominal voltage		≥0,90% with 12-pulse + Filter								
Flexi Power Walk-In	second	5 to 120 (selectable)								
<b>Battery &amp; DC Parameters</b>										
Battery Type		VRLA (Valve Regulated lead Acid) or Wet or NiCd								
Nominal Battery Bus	Vdc	396 (Float Voltage: 446V)					480 (F. V.: 540V)	396 (F. V.: 446 V)	480 (F. V.: 540V)	
End-Cell Voltage	Vdc/Cell	Selectable from 1,65 to 1,90 (for VRLA/Wet Cells)								
DC ripple voltage in float & Const V Ch.mode	%	<1 (RMS value)								
Temperature compensated Battery Charging		Optional								
<b>Output Parameters</b>										
Inverter Type		IGBT-based Sine-Sine PWM Cotrolled								
Output Power	KW	96	128	160	240	320	400	480	640	
Output Voltage	Vac	380/400/415* (400V:nominal) 3-phase, 4-w								
Output Voltage Regulation	%	+/- 0,5 (3 phase RMS average)								
Output Frequency	Hz	50 or 60								
Output Frequency Regulation	%	+/- 0,05								
Output Voltage THD at nominal voltage	%	1 (typ), 2% (max)								
Capability to handle High Crest Factor Load		3:1 (compliant with IEC 62040-3)								
Capability to handle Step Load	%	0-100 or 100-0								
Transient Recovery	m seconds	10 (recovery to 95% of the voltage level)								
Capability to handle Leading PF Load		Up to 0,7**								
Voltage Displacement	°el	120° +/- 1° el (with 100% unbalanced load)								
Overload Conditions	%FL	110 for 60 minutes 125 for 10 minutes 150 for 1 minutes								
<b>System Parameters</b>										
UPS Efficiency (without any power option)	%	Up to 93,5 (depends on rating & operating condition)								
<b>Physical Parameters &amp; Standards</b>										
Width (applicable to 6 pulse version)***	mm	1250			1640	2460	Not Applicable			
Width (applicable to 12 pulse version)***	mm	1250	1250	1640	2280	2460	2460	3200	4410	
Depth	mm	850					1000			
Height	mm	1900								
Weight 6p (approx.)	Kg	1000	1200	1350	1850	2400	Not applicable			
Weight 12p (approx.)	Kg	1400	1475	1725	2540	3100	4200	4500	5050	
Colour		Ral 7035								
Front door Opening (for better Serviceability)		More than 180°								
Degree of Protection for UPS Enclosure		IP 20 even with front door in opened condition								
Standards & Conformities		IEC 62040-3, IEC 62040-2, IEC 62040-1-1, CE Mark ; EN 62040-1-1, EN 50091-2, EN62040-3, EN 60950, EN 60529 and VFI 111								
<b>Enviromental Parameters</b>										
Storage Temperature Range	°C	-25 to 70 (UPS) & -20 to 30 (Battery)								
Operating Temperature Range	°C	0 to 40 (UPS) & 20 +/- 5 (Battery)								
Relative Humidity	%	0 to 95 ( non condensing)								
Maximum Altitude above MSL (Mean Sea Level)	m	1000 (as per IEC 62040/3)								

\* 4-5% more power output for 415V input & output ; \*\* with suitable derating; \*\*\*with OR without input harmonic filter

While specifying the parameters here, it is assumed that, extremes of all the conditions do not apply simultaneously.

While every precaution has been taken to ensure accuracy and completeness in this brochure, Liebert Corporation assumes no responsibility, and disclaims all liability for damages resulting from use of this information or for any errors or omissions. © 2004 Liebert Corporation. All rights reserved throughout the world. Specifications subject to change without notice. All names referred to are trademarks or registered trademarks of their respective owners.

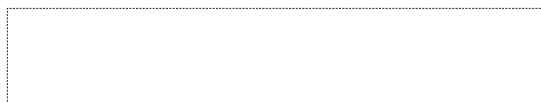

Liebert HIROSS UPS Sales Headquarters  
Via Leonardo da Vinci,8  
35028 - Piove di Sacco (PD)  
tel.+39 049 9719111 fax +39 049 9719317

Liebert HIROSS Services Headquarters  
Via Leonardo da Vinci,8  
35028 - Piove di Sacco (PD)  
tel.+39.049 9719111 fax +39 049 9719257  
service@liebert-hiross.com

Emerson Network Power Ltd - UK  
Fourth Avenue, Globe Park - Marlow  
Buckinghamshire - SL71YG  
tel. +44 1628 403200 fax +44 1628 403203

<http://ups.liebert-hiross.com>